

EIPS2

INTERNAL GEAR PUMPS



 **ECKERLE**
HYDRAULIC DIVISION

Internal gear pump Type EIPS 2 with constant displacement volume



EIPS 2

Characteristics

- Internal gear pump with axial and radial gap compensation
- Radial compensation with segments
- Pressure cast cover
- Field of application: Mobile hydraulic systems, e.g. for fork lifts
- Direct fixture
- Low noise
- Long service life
- Low pulsation (pressure pulsation ~ 2%)

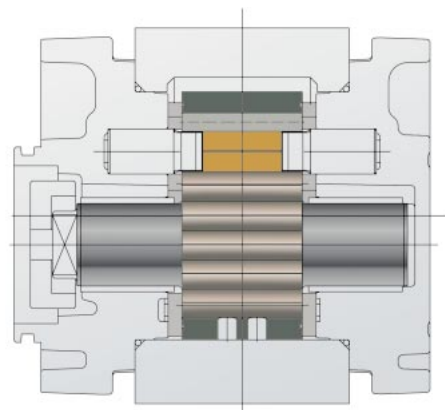
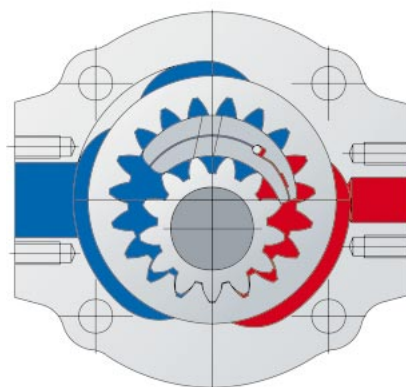

Technical Data:

Rated Size NG	005	006	008	011	013	016	019	022	025	
Spec. volume V_{th} [cm ³ /U]	5.4	6.4	7.9	10.9	13.3	15.8	19.3	22.2	25.2	
Continuous operating pressure [bar]	250									
Peak operating pressure [bar] max.10sec.15% dutycycle				320			300		280	
Cut-in pressure peak 100 ms [bar]				350			325		300	
Max. speed [min ⁻¹]	4,200			4,000			3,600			
Rated speed [min ⁻¹]	200 – 4,000			200 – 3,600			100 – 3,000			
Operating viscosity [mm ² /s]	10 – 300									
Starting viscosity [mm ² /s]	2.000									
Operating temperature [°C]	-20 to +100									
Operating medium	HL – HLP DIN 51 524 Teil 1/2									
Max. medium temperature [°C]	120									
Min. medium temperature [°C]	-40									
Max. ambient temperature [°C]	80									
Min. ambient temperature [°C]	-40									
Max. admission pressure (intake side) [bar]	2 bar absolute									
Min. admission pressure (intake side) [bar]	0.8 bar absolute (start 0.6)									
Weight appr. [kg]	2.9	3.0	3.1	3.3	3.5	3.6	3.8	4.0	4.2	
Degree of filtration	NAS 1638, Class 9, filter with $\beta_{10} \geq 100$									
Life expectancy	1x 10 ⁶ LW against peak operating pressure									
Efficiency η_{vol} [%]	91	92	93	93	94	95	95	95	95	
Efficiency η_{hm} [%]	90	90	91	92	92	93	93	93	93	
Pump noise* (measured in sound chamber) dB[A]	55	56	58	59	60	61	62	63	64	
	n = 1.450			$\Delta p = 250$ bar			T = 50 °C		Medium: HLP 46	
	* Measured in anechoic room of Eckerle Hydraulic Division; Axial microphone distance 1.0 m									



Pump with oldham coupling

Order example: EIPS2 - ___ LD34-10

NG	a	b	c
005	43	82,5	72
006	44	84,5	74
008	45,5	87,5	77
011	48,5	93,5	83
016	53,5	103,5	93
019	57	110,5	100
022	60	116,5	106
025	63	122,5	112

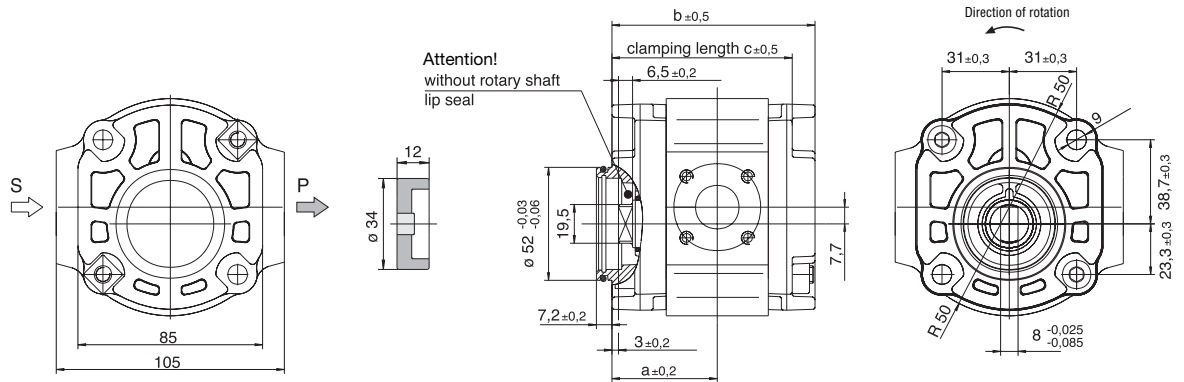

Coupling included in scope of delivery.
Provide M8 DIN 912 fastening screws with DIN 433 plain washer, tightening torque M=25+5 Nm

Pump with SAE-2-whole flange and splint shaft

Order example: EIPS2 - ___ RB04-10

NG	a	b
005	62	101,5
006	63	103,5
008	64,5	106,5
011	67,5	112,5
013	70	117,5
016	72,5	122,5
019	76	129,5
022 *	79	135,5
025 *	82	141,5

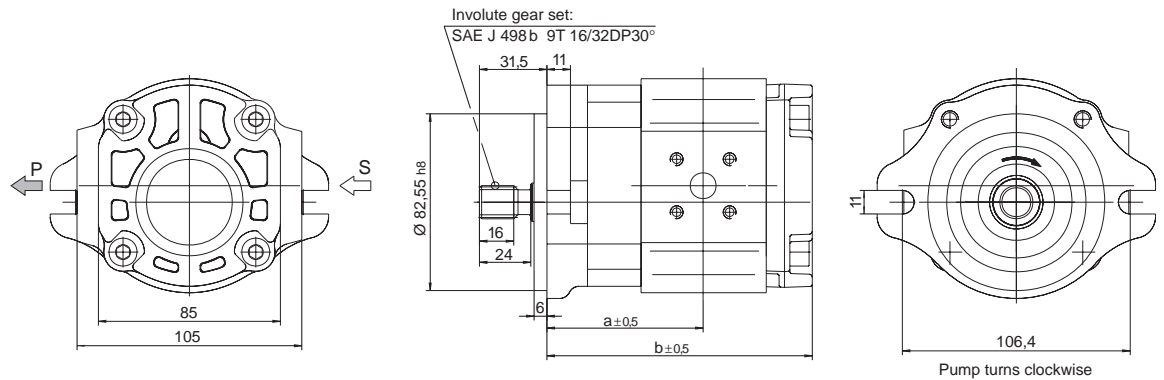

*on request

Pump with SAE-2-whole flange and cylindrical shaft

Order example: EIPS2 - ___ RA04-10

NG	a	b
005	62	101,5
006	63	103,5
008	64,5	106,5
011	67,5	112,5
013	70	117,5
016	72,5	122,5
019	76	129,5
022	79	135,5
025	82	141,5

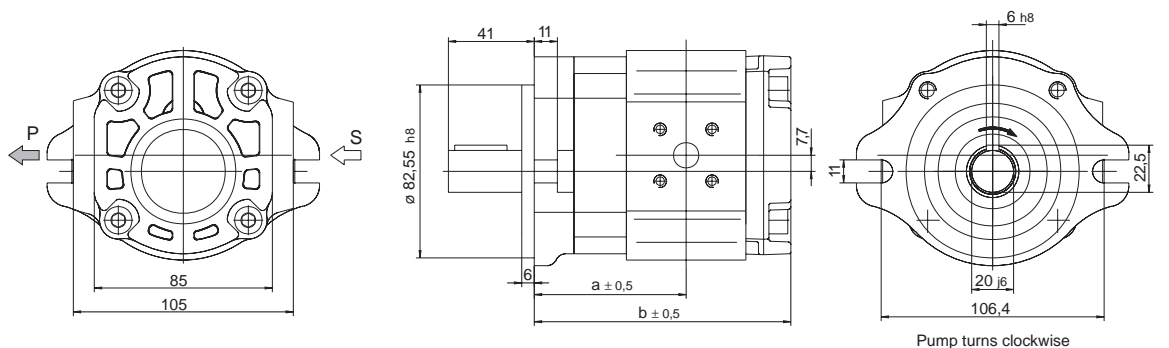

SAE-B flange on request





Pump with cylindrical shaft

Order example: EIPS2 - ___RA34-10

NG	a	b	c
005	43	82,5	72
006	44	84,5	74
008	45,5	87,5	77
011	48,5	93,5	83
013	51	98,5	88
016	53,5	103,5	93
019	57	110,5	100
022	60	116,5	106
025	63	122,5	112

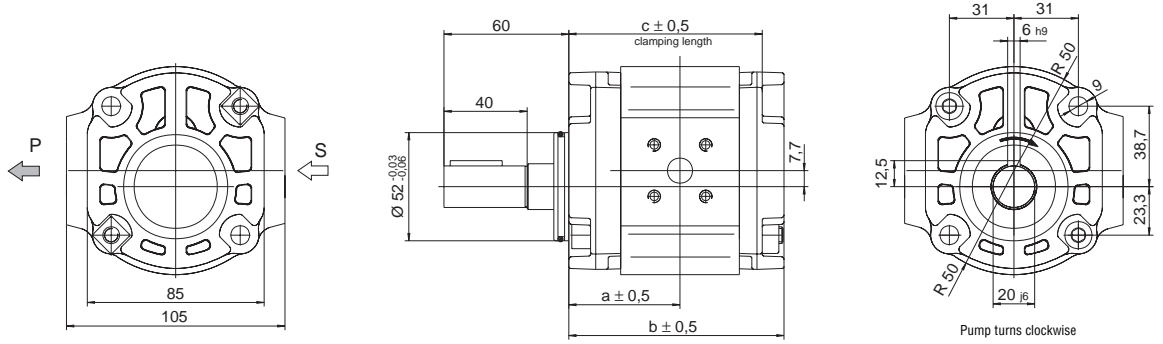

Provide M8 DIN 912 fastening screws with DIN 433 plain washer, tightening torque M=25+5 Nm

Doublepump with AE-2-whole flange and cylindrical shaft

Order example: EIPS2 - ___RK04-10

EIPS2 - ___RD34-10

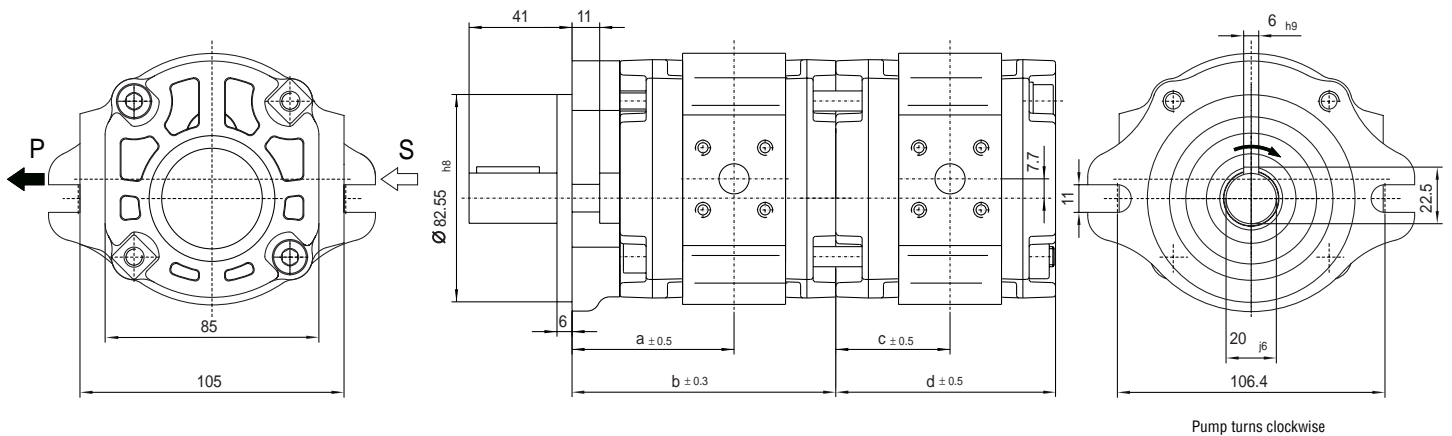

NG	a	b	c	d
005	62	100	43	82,5
006	63	102	44	84,5
008	64,5	105	45,5	87,5
011	67,5	111	48,5	93,5
013	70	116	51	98,5
016	72,5	121	53,5	103,5
019	76	128	57	110,5
022	79	134	60	116,5
025	82	140	63	122,5



EIP S2-011RA34-10 S123

Special version number (not applicable with standard pumps or when the type key is unambiguous)

Revision code 1st number: Change of mounting dimensions
2nd number: Change of pump with same mounting dimensions

Intake and delivery connection 4: Square flanged connection in accordance with DIN 3901/3902
– Other connections on request –

Fastening flange: 0: SAE/A 2-hole centre-Ø 82.55
2: SAE/A B-hole centre-Ø 101.6
3: Direct fixture
– Other flanges on request –

Shaft end A: Cylindrical
B: SAE gear
D: Two-flange engagement
K: Cylindrical with cone
L: SAE gear with cone
N: Two-flange engagement with cone
(cone = add-on facility for additional pumps to create multiple-flow pumps)

Sense of rotation R: Clockwise
L: Anticlockwise

Rated size, three digits

Overall size

Type S: Segmental pump

Eckerle internal gear pump

Order example

EIPS2 - 005 LD34 - 10

Segmental pump overall size 2 with 5.4 cm³/rev., anti-clockwise rotation, two-flange engagement, direct fixture, square flange connection, revision code 10

Intake and delivery connections

Intake connection

NG 005-016

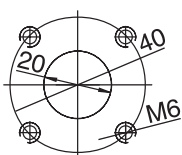

NG 019-025

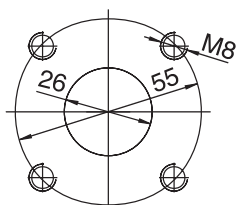

Delivery connection

NG 006-025

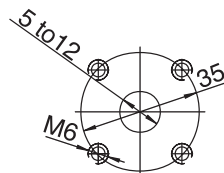

Thread depth M6 and M8 = 12 mm
All dimensions stated in mm
-- other connections on request --





Volumetric flow

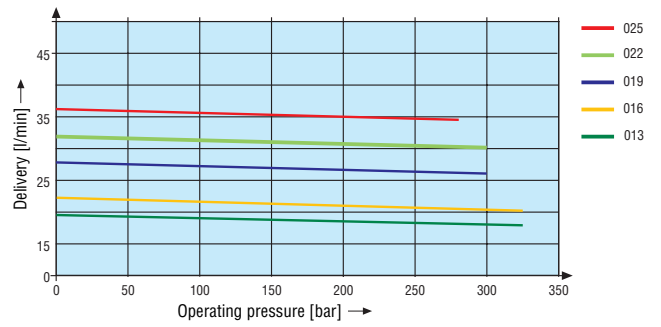
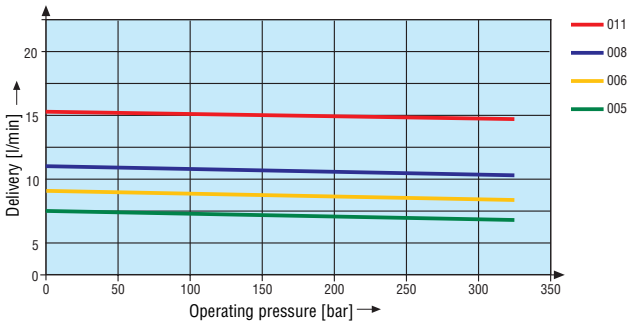

Efficiency

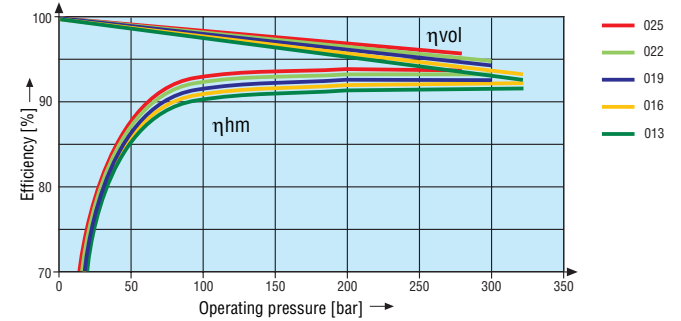
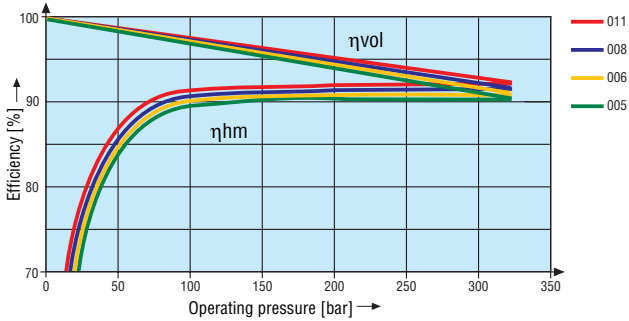

Drive output

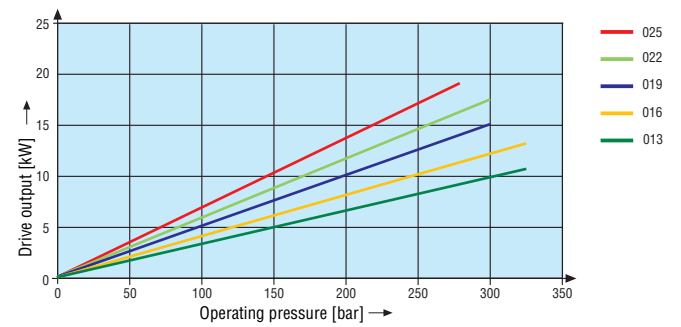
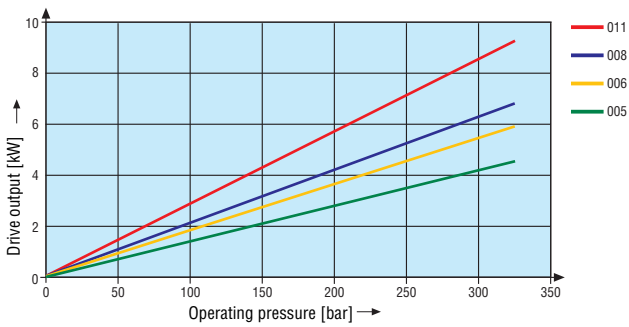

Sound pressure level

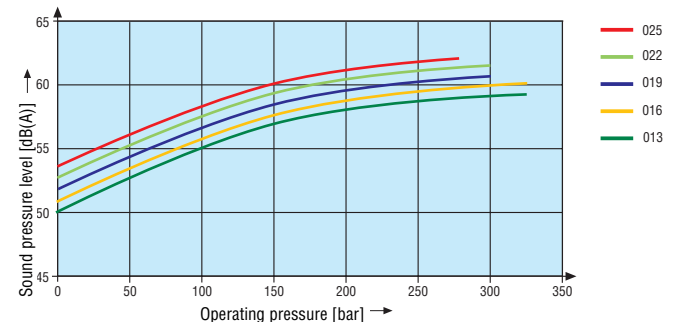
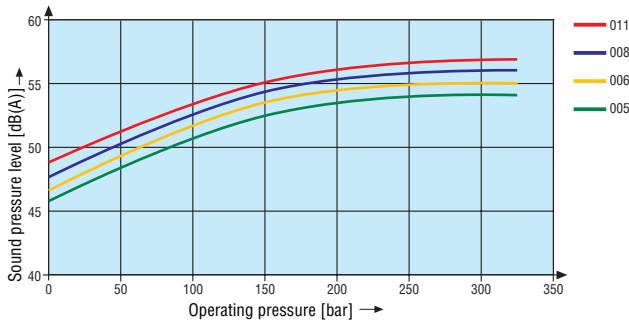

Measurement conditions: Speed 1450 rpm, viscosity 46 mm²/sec., operating temperature 40°C
 Sound pressure measured in low-reflection anechoic room in accordance with DIN 45 635 sheet 26;
 Microphone distance 1.0 m axial.



Commissioning

- Check whether the unit has been carefully and correctly mounted.
- Fill with pressure fluid only using a filter with the required minimum retention rate.
- Observe the arrow indicating the correct sense of rotation.
- Start up the pump in no-load operation and run without pressure for a few seconds to ensure sufficient lubrication.
- Never allow the pump to run without oil.
- The pump has to be bled before building up pressure against a valve. Wear is covered by running dry.
- If the pumped oil still contains bubbles of air after appr. 20 seconds, investigate the cause.

Once the target operating values have been reached, check the pipe connections for leaks. Also check the operating temperature.

Project processing instructions

When using internal gear pumps, we recommend paying particular attention to the following information:

Characteristic values

All specified characteristic values are dependent upon production tolerances and apply under certain outline conditions. Please note that variance is accordingly possible, and that certain outline conditions (such as viscosity or temperature) and also characteristic values can alter.

Characteristic curves

When configuring the drive motor, please pay attention to the maximum possible application data as indicated in the characteristic curves on page 6.

Venting

- Prior to initial commissioning, we recommend filling the pump housing with oil. This enhances operating safety and prevents wear in the event of unfavourable mounting conditions.
- On initial commissioning, drain off oil containing bubbles during pressure-less circulation of the oil by carefully opening the pressure flange (it may be advisable to provide a splash guard). Only when the emerging oil is free of bubbles should the screw union be tightened with the specified tightening torque.

General

- Pumps supplied by us have been performance and function tested. Any attempts to modify the pump in any way will result in loss of warranty cover!
- Repairs may only be performed by the manufacturer or by authorized dealers and branches. No warranty can be accepted for unauthorized repairs.

Noise

The sound pressure level values specified on page 6 are measured on the basis of DIN 45 635, sheet 26. This means that only the noise emission of the pump itself is indicated. Environmental influences (installation location, pipework etc.) are not taken into consideration. These values apply in each case to only one pump.

In the case of internal gear pumps, the excitation of valves, pipelines, machine parts etc. is minimal due to the low discharge flow pulsation (appr. 2 – 3%).

Despite this, however, under unfavourable circumstances the sound pressure level at the mounting location of the unit can be 5 to 10 dB(A) higher than the value for the pump itself.

Important remarks

- Installation, maintenance and repair of pumps may only be performed by suitably qualified and authorized personnel who have received the relevant instruction.
- Pumps may only be operated in accordance with the specified ratings.
- The pump may only be operated when in flawless condition.
- Before performing any work on the pump, always depressurize the system.
- Any conversions or modifications of the pump which affect safety or functional characteristics are not permissible.
- Ensure that the necessary protective gear (such as coupling safeguards) is in place and that existing safeguards are not removed.
- Always check the firm fit of all fastening screws (observe the specified tightening torque).
- Ensure that the generally applicable safety and accident prevention regulations are observed.





Drive system

Electric motor + pump mount + coupling + pump

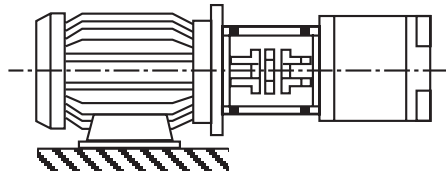

- No radial or axial forces may be permitted to act on the pump drive shaft.
- The motor and pump must be precisely aligned.
- Always use a coupling which will permit compensation for any shaft displacement.
- When mounting the coupling, avoid applying axial force, i.e. never attempt to press or knock into place using a hammer or similar instrument.

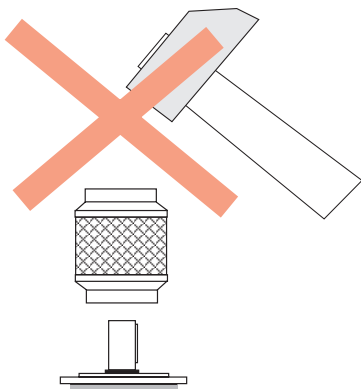

Fluid tank

- Adjust the useful volume of the tank to the operating conditions.
- Never exceed the admissible fluid temperature. If necessary, provide a cooler.

Pipes and connections

- Remove the protective plug at the pump
- We recommend using seamless precision steel pipes in compliance with DIN 2391 and detachable pipe connectors.
- Select a suitable clear width for pipes and connections (intake speed max. 1–1.5 m/s).
- Absolute admission pressure max. 2 bar.
- Carefully clean pipelines and screw unions prior to mounting.

Pipe routing recommendation

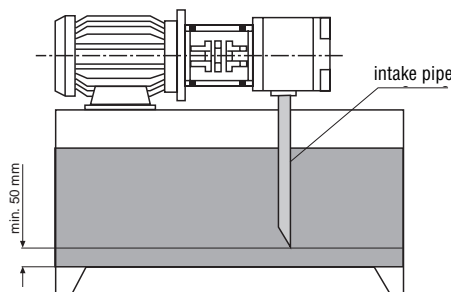

- Return line fluid must not under any circumstances be permitted to directly re-enter the system via the intake pipe, i.e. ensure the greatest possible distance between the intake and the return line pipe.
- Return line pipe has to be under oil level at all times.
- When assembling pipelines, ensure that the suction and pressure seal is completely intact.

Filters

- Wherever possible use return or pressure filters (use suction filters only in conjunction with vacuum switches / dirt accumulation indicators).

Pressure fluid

- We recommend using brand name hydraulic oils HL-HLP DIN 51524 part 1 + 2
- Different oil types must not be mixed, as this can result in decomposition and a reduction of lubrication capability.
- Depending on the operating conditions, the fluid must be renewed at certain intervals. When changing the fluid, the tank must be cleaned of residues.

Mounting positions

